

SOLUTION



Single Crank Press

TP FX SERIES

TP-15FX / TP-25FX / TP-35FX / TP-45FX / TP-60FX / TP-80FX / TP-110FX / TP-150FX / TP-200FX

Press



Industry leading technology which has always been ahead of its time the Traditional **CRANK PRESS!**

Since the introduction of the TP Series, it has always been at the leading edge of technology in press shops around the world. Besides its high versatility of functions that have surpassed the needs of our customers, the TP-FX Series is also digital network ready and assists in the visualization of operation conditions and maintenance information. Eco-counter and eco-idling functions save on energy, and improves its efficiency.



Single Crank Press

TP FX SERIES

TP-80FX

TP-150FX

*Options are included in photos.

TP-FX Series Technologies and Functions

1 Functionality: Improved Operator Interface Terminal (OIT) and machine data management

Pendant control panel

Standard TFT color screen provides better visibility and operator interface.

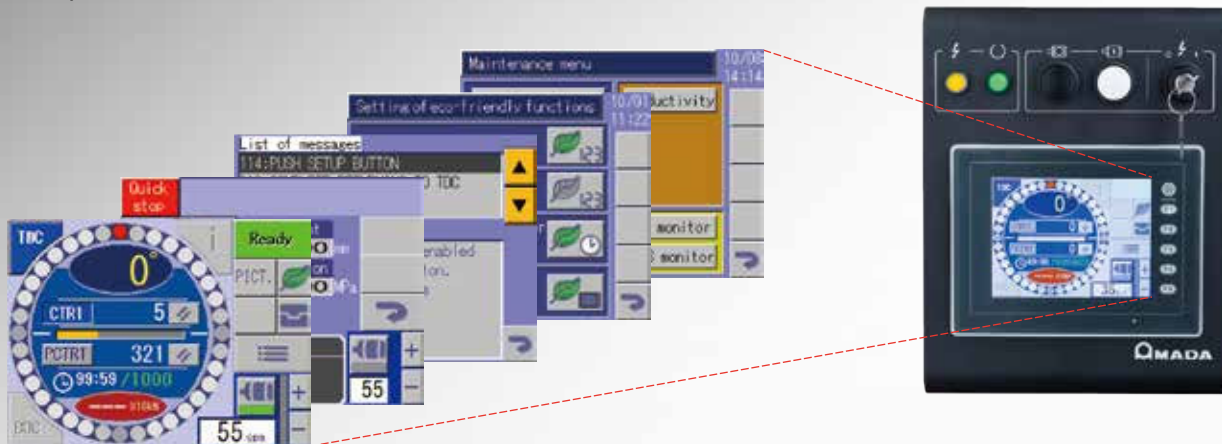

Operator Interface Terminal (OIT) display

Newly designed display layout provides better visibility and intuitive operation.

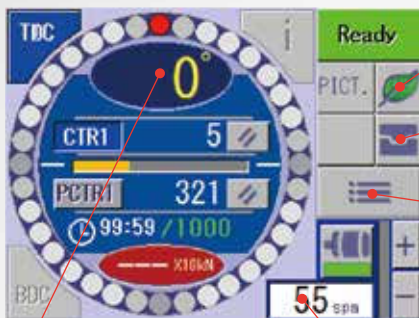

Eco-function settings button
Shows the eco-function settings display.

Setup button
Shows the setup display convenient to use when changing dies.

Menu button
Shows the menu display for die information and maintenance information among other information.

Rotary cam setting display

No.	name	ON	OFF	mode	
L1	ejector	0	0	OFF	TIMR
L2		0	0	OFF	
L3		0	0	OFF	
L4		0	0	OFF	
L5		0	0	OFF	
L6		0	0	OFF	
L7		0	0	OFF	
L8		0	0	OFF	



By utilizing the numerical keypad, one can set the corresponding counters, cam, or stroke counts.

Two-hand control panel with protective guard rings

New protective guard rings improve operability. A thinner control panel (0.59" thinner than conventional panels) makes operation more comfortable for the seated operator. Many AMADA stamping presses standardize pictographs and English labels, making an operator feel at ease at using any AMADA press equipment.



TP-FX Series Technologies and Functions

Die setup information and operation

Die information for up to 20 dies, and expandable up to 200, can be stored in the machine. The stroke count and rotary cam data settings can be changed all at once by selecting the different die entries.



Program save and select



Die information

Maintenance management

The TP-FX Series simplifies maintenance, showing a record of oil change history, inspection history, and number of total operations at the touch of a button.

This feature lengthens the life of the equipment and promotes increased up-time.

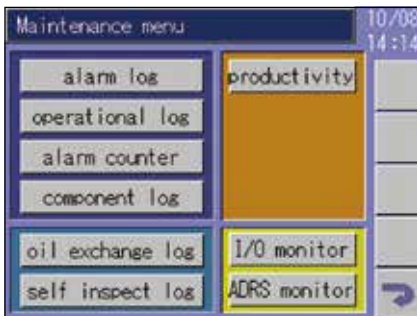

Maintenance management menu

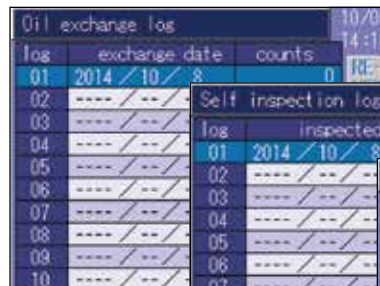

Oil change history

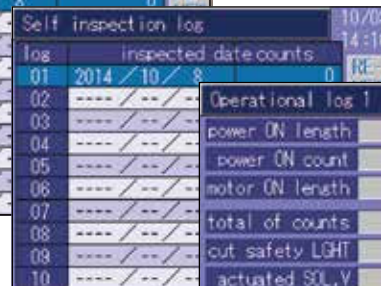

Special voluntary inspection history

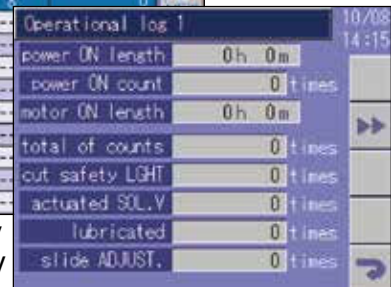

Operation counts

Superior safety

TP-FX Series presses incorporate safety PLCs meeting safety standard ISO 13849-1, which increases reliability in safety.

2 Flexibility: Performance-proven functions that meet demanding production needs

Traditional AMADA wet transmission

Rotation from the flywheel is transferred to the slide through a planetary-gear transmission (for medium-capacity models) or a two-stage reduction-gear transmission (low-capacity models).

The results are higher reduction ratio, torque, and energy. A multiple-disc clutch-brake unit reduces air consumption when the clutch is turned on and off and transmits an appropriate braking force.

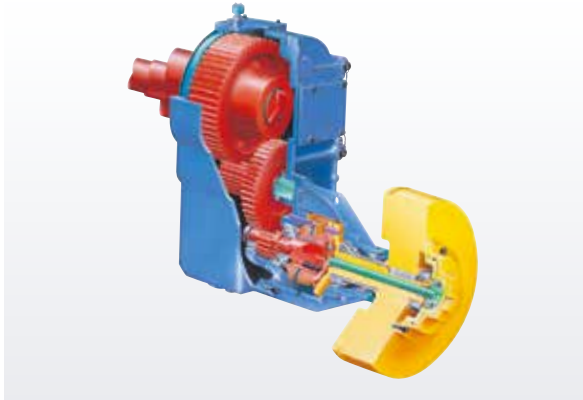

Two-stage reduction-gear transmission
TP-25FX ~ TP-80FX

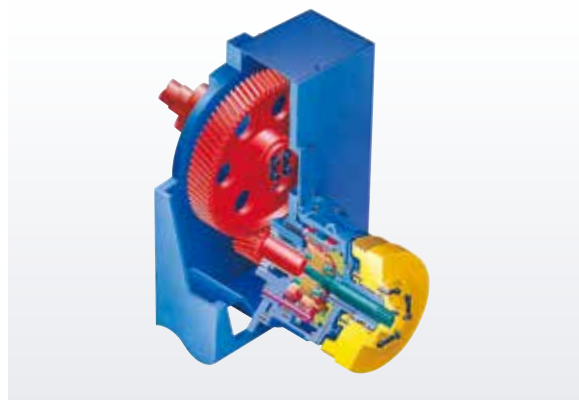

Planetary-gear transmission
TP-110FX ~ TP-200FX

Die height displayed in minimum increments of 0.01 mm*

*Except for TP-15FX, TP-25FX, and TP-35FX

Standard motorized Slide adjustment can adjust the Die height in minimal increments of 0.00039" (0.01mm). This promotes quick and easy Die changes.



Highly rigid frame and bolster

Frame deflection is minimized by computer-aided strain analysis to meet precision stamping needs. Consequently, stamping accuracy is improved and the part rejection rate is reduced.

The instantaneous deflection of the bolster by the stamping load is minimized to achieve stable stamping quality and longer die life.



Die cushions

There are available pneumatic die cushions with many years of proven performance and excellent durability, and hydropneumatic die cushions to expand the drawing range.



Pneumatic die cushion

TP-FX Series Technologies and Functions

3 Future Facing: Expanding possibilities with automation

Automation of press processing through system upgrade

Due to combine a stamping press machine with peripheral equipment, we support the automation of stamping press processing. A variety of lineups according to the processing content and high-operability are realized, contributing to high-precision processing.

Example for system upgrade:
Straightener-feeder **LCC03KR3**



APINES

APINES is AMADA Press machine Information Network System.

Visualization of press operating conditions and maintenance information with touch screen PC. The Ethernet is equipped as standard.

- General-purpose presses to servo presses are all digital network ready
- Real-time shop floor monitoring
- Operation and production history, time chart
- Alarm information, maintenance information
- Tablet and smartphone ready



Shop area monitor



Operation time chart

Network-compatible stamping press machines

Visualization of stamping press operation status and maintenance information by PC

- Digital network connection is possible from general-purpose to servo presses.

- Real-time monitoring of presses connected to the factory network.
- Alarm and maintenance information can be checked and saved in real-time.

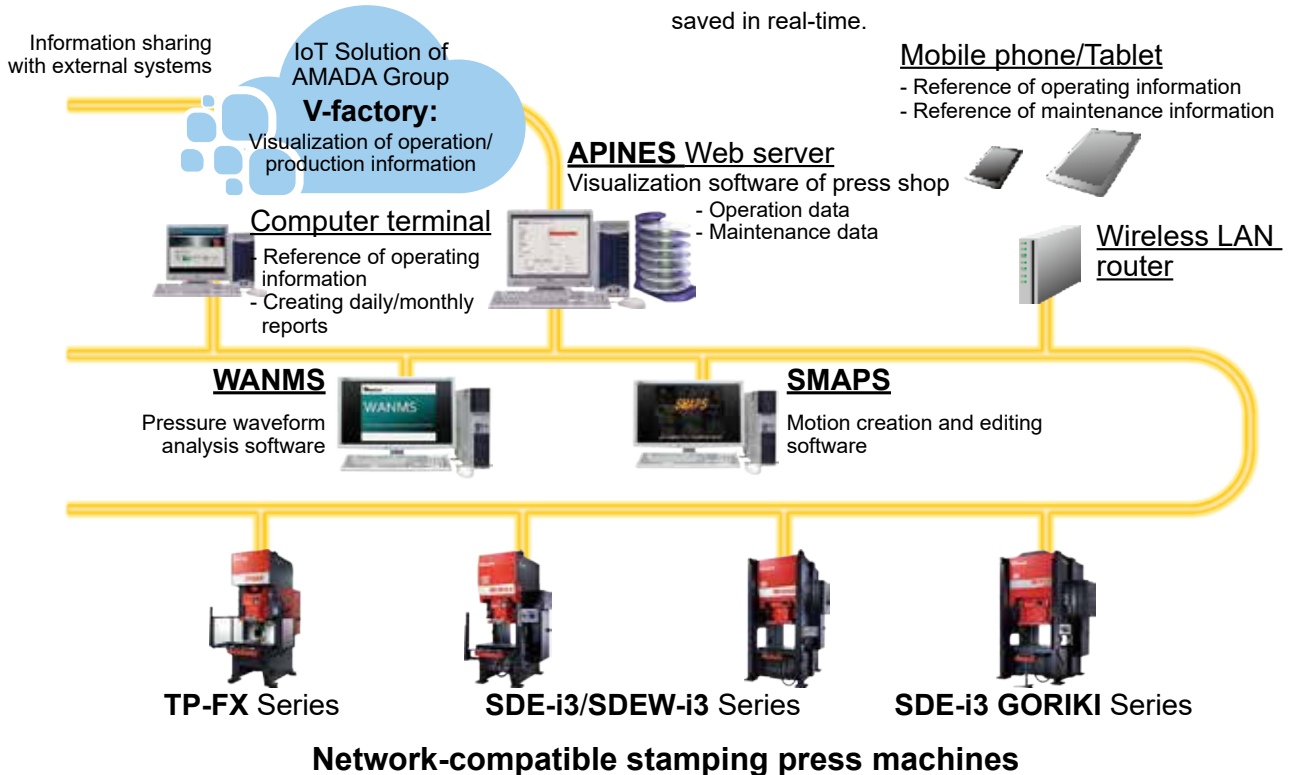

Eco-functions reduce power consumption

Advanced eco-functions are installed to achieve lower power consumption as compared with conventional machines.

Eco-counter function

When the production count reaches a preset value, the motor automatically switches to idle mode and draws less power.

Eco-idling function

When standby time reaches a preset value, the motor automatically switches to idle mode and consumes less power.

Touch screen blackout function

When the touch screen has not been operated for a preset time, the screen will shut off to reduce power consumption.

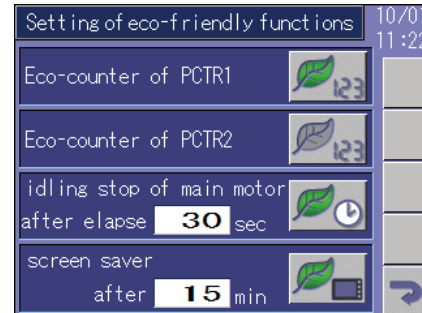

Power consumption comparison

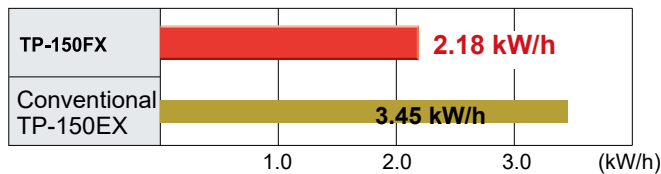

37% reduction

Power consumption calculation conditions

- Production stroke count: Maximum stroke count x 0.7
- Load operation: 30 min
- Standby (setup): 10 min

Processing Examples with Sample Workpieces

Noise and vibration reduction

Material: Cold Rolled Carbon Steel
(JIS: SPCC)

Material: Steel for cold deep drawn extra
(JIS: SPCE)



Dimension Tables for Die Space

■ TP-FX Series

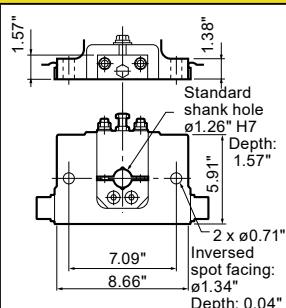
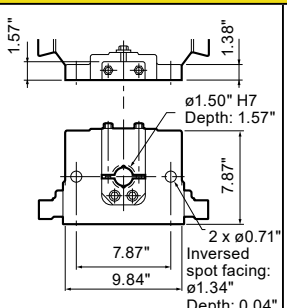
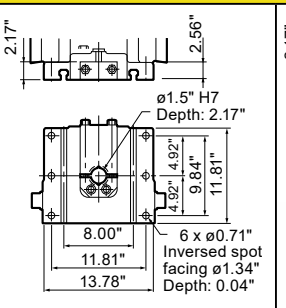
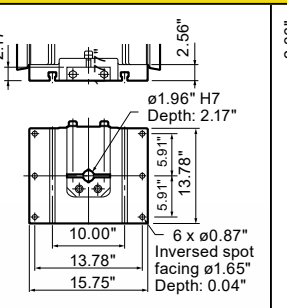
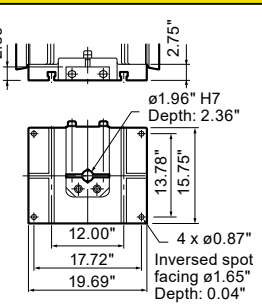
TP-15FX	TP-25FX	TP-35FX	TP-45FX	TP-60FX
Standard slide bottom drawing				
 <p>Standard shank hole $\phi 1.26''$ H7 Depth: 1.57" 5.91" 7.09" 8.66" 2 x $\phi 0.71''$ Inversed spot facing: $\phi 1.34''$ Depth: 0.04"</p>	 <p>$\phi 1.50''$ H7 Depth: 1.57" 7.87" 9.84" 2 x $\phi 0.71''$ Inversed spot facing: $\phi 1.34''$ Depth: 0.04"</p>	 <p>$\phi 1.5''$ H7 Depth: 2.17" 8.00" 11.81" 13.78" 4.92" 4.92" 9.84" 11.81" 6 x $\phi 0.71''$ Inversed spot facing $\phi 1.34''$ Depth: 0.04"</p>	 <p>$\phi 1.96''$ H7 Depth: 2.17" 10.00" 13.78" 15.75" 5.91" 5.91" 13.78" 6 x $\phi 0.87''$ Inversed spot facing $\phi 1.65''$ Depth: 0.04"</p>	 <p>$\phi 1.96''$ H7 Depth: 2.36" 12.00" 17.72" 19.69" 13.78" 15.75" 4 x $\phi 0.87''$ Inversed spot facing $\phi 1.65''$ Depth: 0.04"</p>

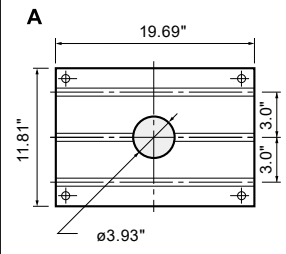
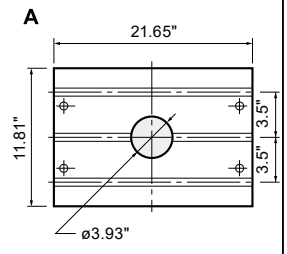
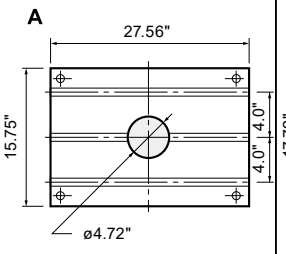
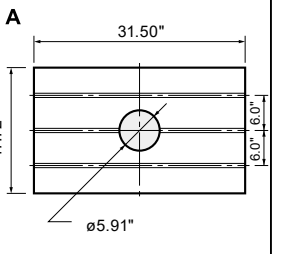
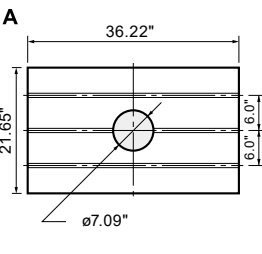
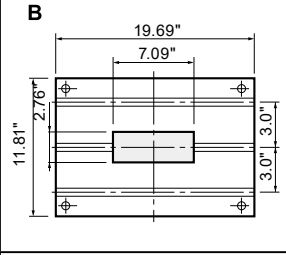
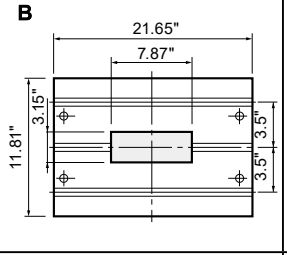
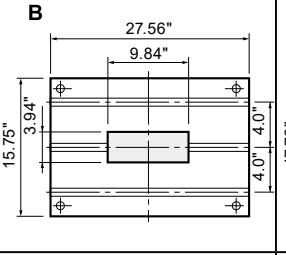
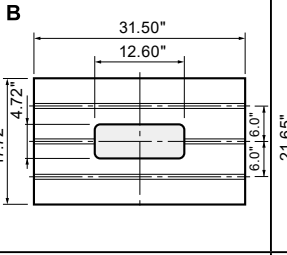
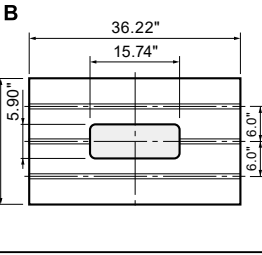
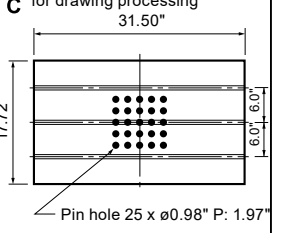
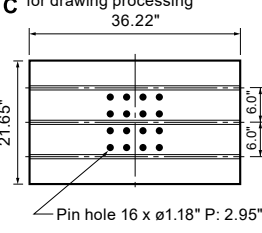
Bolster plate drawing				
 <p>A 19.69" 11.81" $\phi 3.93''$ 3.0" 3.0"</p>	 <p>A 21.65" 11.81" $\phi 3.93''$ 3.5" 3.5"</p>	 <p>A 27.56" 15.75" $\phi 4.72''$ 4.0" 4.0"</p>	 <p>A 31.50" 17.72" $\phi 5.91''$ 6.0" 6.0"</p>	 <p>A 36.22" 21.65" $\phi 7.09''$ 6.0" 6.0"</p>
 <p>B 19.69" 7.09" 11.81" 2.76" 3.0" 3.0"</p>	 <p>B 21.65" 7.87" 11.81" 3.15" 3.5" 3.5"</p>	 <p>B 27.56" 9.84" 15.75" 3.94" 4.0" 4.0"</p>	 <p>B 31.50" 12.60" 17.72" 4.72" 6.0" 6.0"</p>	 <p>B 36.22" 15.74" 21.65" 5.90" 6.0" 6.0"</p>
			 <p>C for drawing processing 31.50" 17.72" 6.0" 6.0" Pin hole 25 x $\phi 0.98''$ P: 1.97"</p>	 <p>C for drawing processing 36.22" 21.65" 6.0" 6.0" Pin hole 16 x $\phi 1.18''$ P: 2.95"</p>

T-slot details

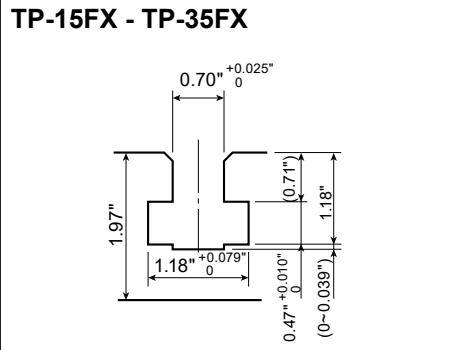
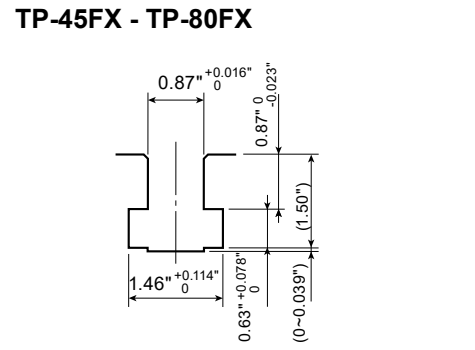
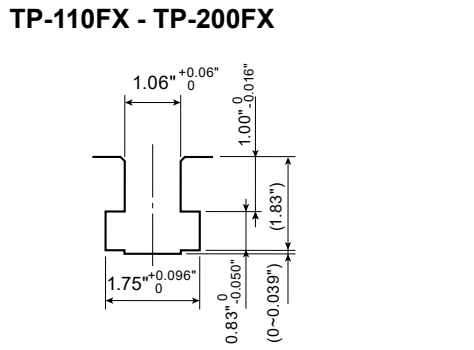
<p>TP-15FX - TP-35FX</p>  <p>0.70"^{+0.025"} 1.97" 1.18"^{+0.079"} 0.71" 1.18" 0.47"^{+0.010"} (0-0.039")</p>	<p>TP-45FX - TP-80FX</p>  <p>0.87"^{+0.016"} 0.87"^{-0.023"} 1.46"^{+0.114"} 0.63"^{+0.078"} (0-0.039") (1.50")</p>	<p>TP-110FX - TP-200FX</p>  <p>1.06"^{+0.06"} 1.00"^{-0.016"} (1.83") 1.75"^{+0.096"} 0.83"^{-0.050"} (0-0.039")</p>
--	---	---

TP-80FX	TP-110FX	TP-150FX	TP-200FX
----------------	-----------------	-----------------	-----------------

Standard slide bottom drawing

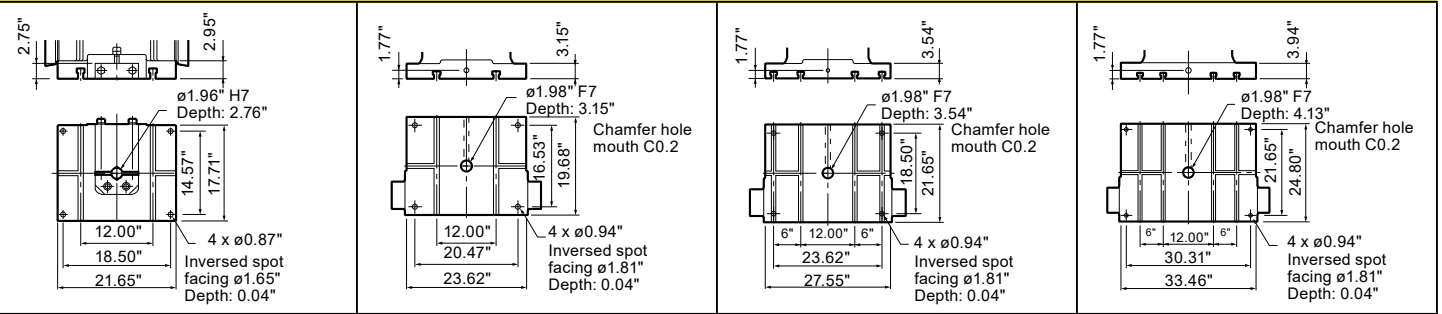

Bolster plate drawing

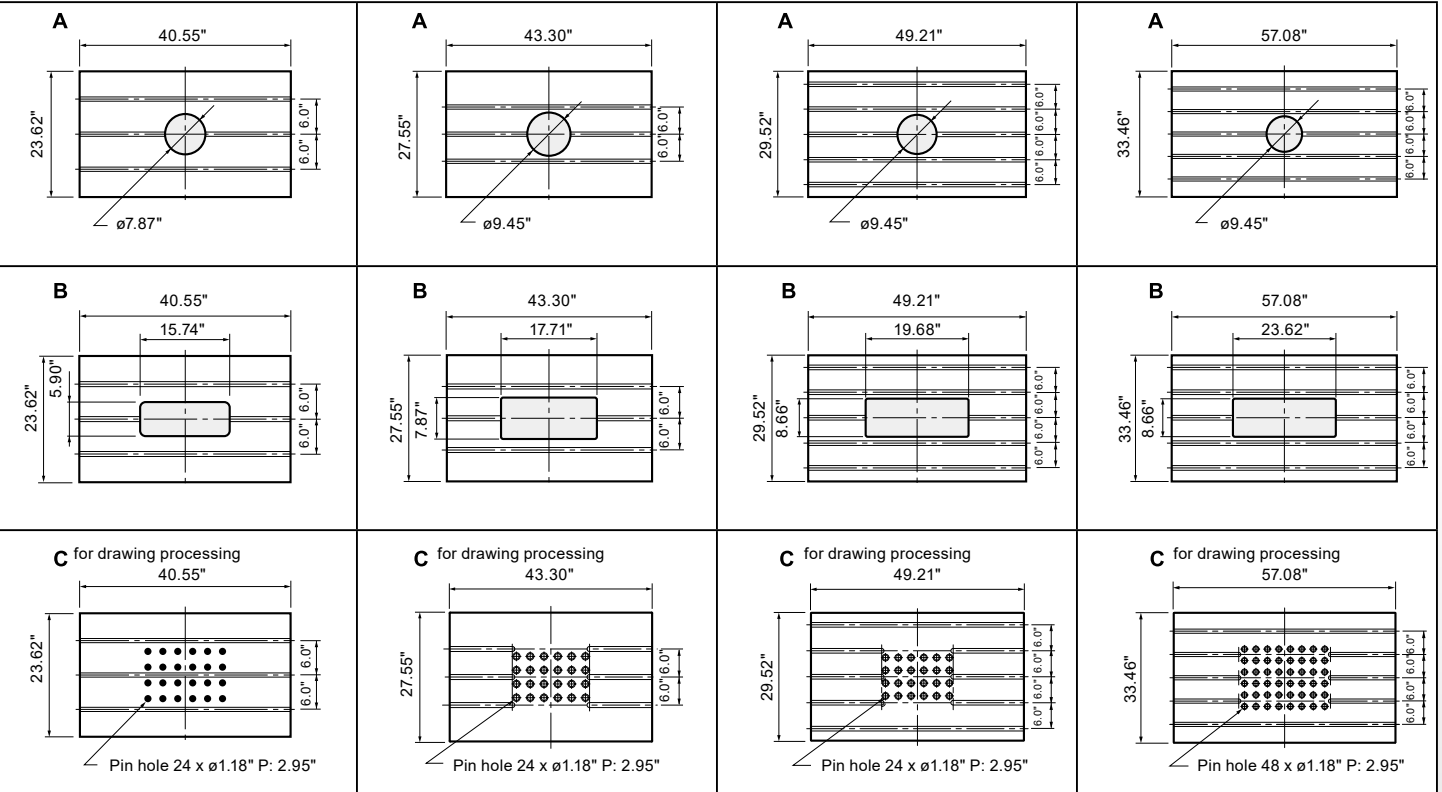

Cushion pin hole details

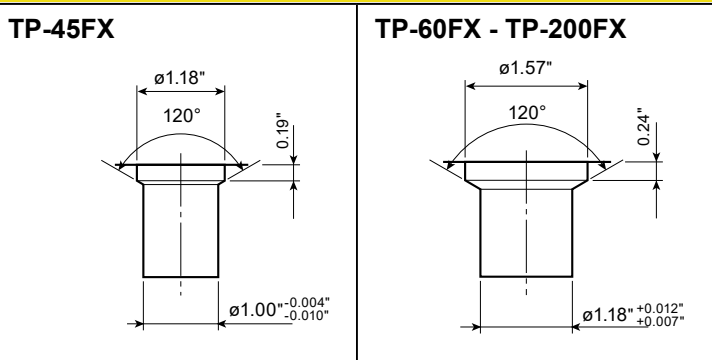

Specifications and Dimension Drawings

■ Machine specifications

Machine model		TP-15FX	TP-25FX	TP-35FX
Capacity	short ton	16.5	27.5	38.5
Tonnage rating point above BDC	inch	0.118	0.196	0.216
Strokes per minute	min ⁻¹	70 ~ 140	70 ~ 120	60 ~ 100
Stroke length	inch	2.362	3.149	4.330
Flywheel energy	kJ	0.5 ~ 2.1	1.0 ~ 2.9	3.3 ~ 9.1
Die height	inch	7.874	8.661	9.842
Slide adjustment	inch	1.574	1.968	2.165
Slide face dimentions (LR x FB)	inch	8.661 x 5.905	9.842 x 7.874	13.779 x 11.811
Bolster dimensions (LR x FB x T)	inch	19.685 x 11.811 x 1.968	21.653 x 11.811 x 1.968	27.559 x 15.748 x 2.362
Main motor	kW // (HP)	1.5 x 4 // (2.0)	2.2 x 4 // (2.9)	3.7 x 4 // (4.9)
Machine mass	lbs.	2,645.5	3,747.8	5,732.0
Slide adjustment type		Manual	Manual	Manual
Lubrication system		Manual grease	Manual grease	Automatic grease
Variable-speed drive		Inverter	Inverter	Inverter

Machine model		TP-45FX		TP-60FX		TP-80FX	
Specification model		General	Drawing	General	Drawing	General	Drawing
Capacity	short ton	49.5		66.0		88.0	
Tonnage rating point above BDC	inch	0.413	0.275	0.259	0.177	0.275	0.188
Strokes per minute	min ⁻¹	55 ~ 100		45 ~ 85		40 ~ 75	
Stroke length	inch	3.937	5.511	4.724	6.299	5.118	7.086
Flywheel energy	kJ	9.6 ~ 31.8		13.2 ~ 47.0		14.0 ~ 49.1	
Die height	inch	10.039	11.417	11.417	13.188	12.598	13.779
Slide adjustment	inch	2.362		2.755		3.149	
Slide face dimentions (LR x FB)	inch	15.748 x 13.779		19.685 x 15.748		21.653 x 17.716	
Bolster dimensions (LR x FB x T)	inch	31.496 x 17.716 x 4.527		36.220 x 21.653 x 4.921		40.551 x 23.622 x 4.921	
Main motor	kW // (HP)	3.7 x 4 // (4.9)		5.5 x 4 // (7.3)		7.5 x 4 // (10.0)	
Machine mass	lbs.	9259.4		13668.6		16314.0	
Slide adjustment type		Motorized		Motorized		Motorized	
Lubrication system		Automatic grease		Automatic grease		Automatic grease	
Variable-speed drive		Inverter		Inverter		Inverter	

Machine model		TP-110FX		TP-150FX		TP-200FX	
Specification model		General	Drawing	General	Drawing	General	Drawing
Capacity	short ton	121		165		220	
Tonnage rating point above BDC	inch	0.374	0.255	0.314	0.236	0.314	0.236
Strokes per minute	min ⁻¹	35 ~ 65	30 ~ 55	30 ~ 55	25 ~ 45	30 ~ 55	25 ~ 45
Stroke length	inch	5.905	7.874	6.889	8.858	7.874	9.842
Flywheel energy	kJ	13.8 ~ 47.7	15.0 ~ 50.3	19.6 ~ 65.9	21.5 ~ 69.6	33.9 ~ 113.9	37.3 ~ 120.9
Die height	inch	14.370	15.354	15.354	16.929	16.535	18.110
Slide adjustment	inch	3.937		3.937		4.330	
Slide face dimentions (LR x FB)	inch	23.622 x 19.685		27.559 x 21.653		33.464 x 24.803	
Bolster dimensions (LR x FB x T)	inch	43.307 x 27.559 x 5.905		49.212 x 29.527 x 6.299		57.086 x 33.464 x 7.086	
Main motor	kW // (HP)	11 x 4 // (14.75)		11 x 4 // (14.75)		15 x 4 // (20.00)	
Machine mass	lbs.	24,250.8		35,273.9		52,910.9	
Slide adjustment type		Motorized		Motorized		Motorized	
Lubrication system		Automatic grease		Automatic grease		Automatic grease	
Variable-speed drive		Inverter		Inverter		Inverter	

■ Machine outline dimensions

TP-15FX ~ TP-35FX

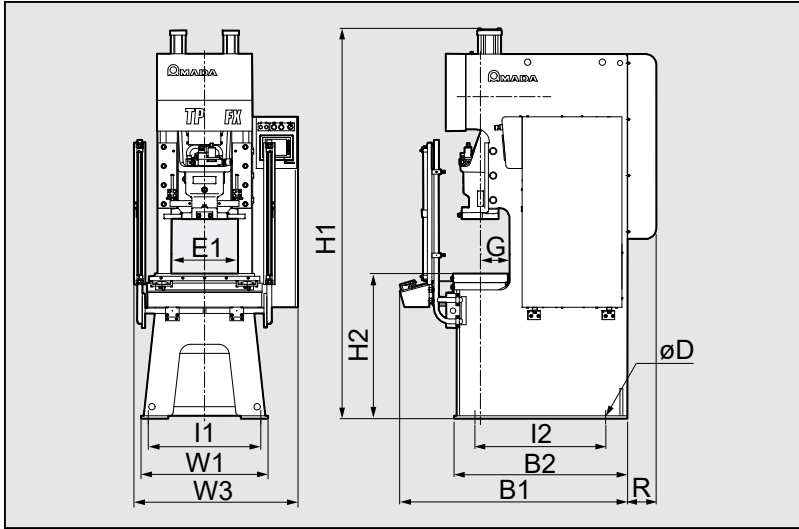

Machine model	TP-15FX	TP-25FX	TP-35FX
W1	22.04"	27.55"	31.49"
B2	30.90"	37.59"	43.50"
H1 * ¹	71.25"	84.84"	95.47"
H2 * ¹	31.49"	31.49"	31.49"
E1	12.44"	14.48"	17.00"
G * ²	6.10"	6.29"	8.26"
W3	35.82"	35.62"	40.35"
B1	43.30"	49.60"	56.69"
R	5.70"	6.29"	6.49"
I1	19.68"	24.40"	28.34"
I2	25.59"	28.34"	34.25"
øD	ø0.94"	ø0.94"	ø0.94"

TP-45FX ~ TP-200FX

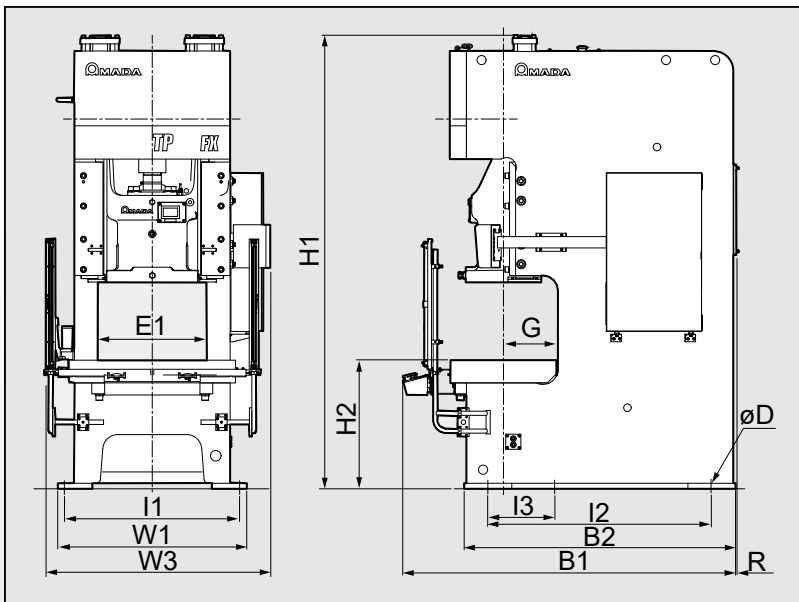

Machine model	TP-45FX	
Specification model	General	Drawing
W1	33.07"	
B2	46.45"	48.22"
H1 * ¹	90.35"	
H2 * ¹	31.49"	
E1	19.29"	
G * ²	9.44"	
W3	44.09"	
B1	61.41"	
R	5.51"	
I1	30.15"	
I2	39.76"	41.53"
I3	-	
øD	ø1.57"	

Machine model	TP-60FX		TP-80FX		TP-110FX		TP-150FX		TP-200FX	
	General	Drawing	General	Drawing	General	Drawing	General	Drawing	General	Drawing
W1	39.37"		42.51"		49.21"		53.93"		60.62"	
B2	55.31"	57.08"	58.85"	61.81"	70.66"		78.93"		88.77"	
H1 * ¹	102.95"	107.87"	109.64"	114.76"	118.11"	121.06"	128.34"	135.23"	143.11"	152.55"
H2 * ¹	33.46"		33.46"		33.46"		35.43"		39.37"	
E1	22.75"		25.11"		28.34"		31.88"		36.22"	
G * ²	11.22"		12.20"		14.17"		15.35"		17.12"	
W3	49.01"		52.75"		58.66"	59.25"	64.17"		70.07"	
B1	69.68"	70.27"	74.60"	74.80"	86.81"		94.68"		105.11"	
R	2.55"		1.37"		0.98"		0.59"		0.59"	
I1	35.43"		38.58"		45.27"		50.00"		55.90"	
I2	47.44"	49.21"	50.39"	53.34"	59.64"		66.14"		75.98"	
I3	-		-		-		22.44"		19.68"	
øD	ø1.57"		ø1.57"		ø1.77"		ø1.77"		ø1.77"	

*1 Bolster height and machine height does not include the height of the anti-vibration isolator.

*2 Dimension from the bolster centerline to the frame edge.

These specifications, machinery, equipment, and appearance are subject to change without notice for reason of improvement.

■ Standard and optional accessories

S: Standard, O: Optional, ---: Not available

Machine name		TP-15FX	TP-25FX	TP-35FX	TP-45FX ~ TP-80FX	TP-110FX ~ TP-200FX
Variable-speed drive: Inverter with forward/reverse selector switch		S	S	S	S	S
Lubrication system	Manual grease	S	S	O	O	O
	Automatic grease	---	---	S	S	S
Mechanical knockout		O	O	O	O	O
Foundation parts: Anchor bolts, shims, and leveling plates		O	O	O	O	O
Vibration isolation system: Rubber isolators		S	S	S	S	S
Slide cap		S	S	S	S	O
Touch screen	5.7"	S	S	S	S	S
	8.4"	---	---	---	O	O
Die information	20 dies	S	S	S	S	S
	200 dies	O	O	O	O	O
Total and preset counter: each 6 digits (x 2)		S	S	S	S	S
Eco-counter and Ethernet		S	S	S	S	S
Software: APINES		O	O	O	O	O
Air ejector with solenoid type: 1 circuit		S	S	S	S	S
Motorized slide adjuster		---	---	O	S	S
Die height counter: Digital display in 0.01 mm increments		---	---	---	S	S
Hydraulic overload protector (OLP)		---	---	S	S	S
Two-hand control system		S	S	S	S	S
Control panel	Stationary	---	---	---	---	---
	Portable stand	S	S	S	S	S
Electronic rotary cam: 4 spare channels		S	S	S	S	S
Die cushion		---	---	---	O	O
Light curtain*		O	O	O	O	O
Waveform Load Monitor (2 channel)		---	O	O	O	O
Die Protection (4 Channel)		O	O	O	O	O

* Warning: The TP-FX model press does not include the O.S.H.A. required Point of Operation guards.

For protection of the operator, Point of Operation guards should be used at all times and are the responsibility of the end user. Safety guards can be added as a line item option.

■ Specifications of digital die cushion as option

Machine name	TP-45FX		TP-60FX		TP-80FX		TP-110FX		TP-150FX		TP-200FX	
	General	Drawing	General	Drawing	General	Drawing	General	Drawing	General	Drawing	General	Drawing
Capacity short ton	1.1	2.53	2.09	3.85	2.53	6.93	8.25		10.45		15.43	
Stroke length inch	1.968	2.755	2.362	3.149	2.755	3.149	3.149		3.149		3.930	
Pad dimensions (LR x FB) inch	9.05 x 8.26	10.23 x 9.25	11.22 x 10.62	14.56 x 10.43	10.23 x 9.25	18.89 x 11.81	17.71 x 12.00		20.00 x 13.50		25.10 x 17.50	

Warning: O.S.H.A. - required point of use guards for protecting the operator are not included and are the responsibility of the end user. These items can be purchased as a turn-key option.

This control meets or exceeds the current requirements for press control systems as defined in O.S.H.A. Standards Section 1910.217, paragraphs (b)13 and (b)14 as published in the Federal Register, July 1, 1991 and ANSI B11.1-2009 as interpreted by AMADA PRESS SYSTEM CO., LTD. Compliance with any local code(s) or requirements is the responsibility of the user.

- ⚠ Before using those products, please read the operator's manual carefully and follow all applicable instructions.
 - Use of this product requires safeguard measures to suit your work. For details, see the safety guide on the home page.
 - The servo presses correspond to the press machines specified in the Ordinance on Industrial Safety and Health. It is necessary to make application for their installation and take any other measure required.
 - Options are included in the photos.
- 
- * Specifications, appearance, and equipment are subject to change without notice for improvement and other purposes.
 - * The official "Model name" for machines and units listed in this catalogue are TP15FX, TP25FX, TP35FX, TP45FX, TP60FX, TP80FX, TP110FX, TP150FX, and TP200FX.
 - * Use these "Model numbers" when contacting authorities to apply for installation, export, or financing.
 - * In this catalogue, if there is a part with a hyphen in it, like "TP-15FX," it is for readability.
 - * The specifications described in this catalogue are for the North American market. Please ask your sales person for details.

©AMADA PRESS SYSTEM CO., LTD. All Rights Reserved.

AMADA PRESS SYSTEM AMERICA INC.

1840 AIRPORT EXCHANGE BLVD #200
ERLANGER, KY. 41018 U.S.A.

